

RECOLHEDOR 8155/40

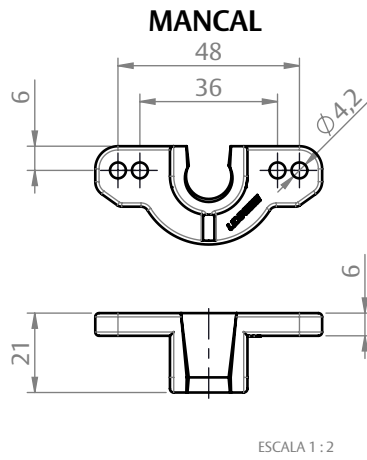

APLICAÇÃO



USINAGEM

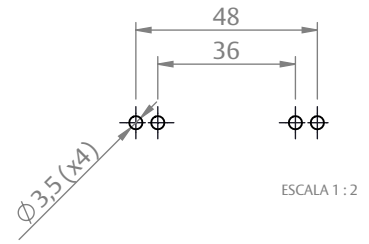

CARACTERÍSTICAS

CODIFICAÇÃO			
COR	CÓDIGO	CATÁLOGO	SISTEMISTA
BCO	9901492	REC8155/40EB-CZ	-
BCO	9901493	REC8155/40EB-CP	
PRT	9901491	REC8155/40EP-CP	

OBSERVAÇÕES:

- COMPRIMENTO DA CINTA: 8,50 M;
- ALTURA MÁXIMA: 2,50 M;
- CALÇO E ADAPTADORES P/ TUBO DE 60 SÃO VENDIDOS SEPARADAMENTE.

COMPOSIÇÃO/CARACTERÍSTICAS:

- CAIXA DO RECOLHEDOR/ ESPELHO/ MANCAL/ PONTEIAS: POLÍMERO
- CALÇO: ALUMÍNIO;
- PARAFUSOS: AÇO INOX;

POLIA C/ REDUTOR

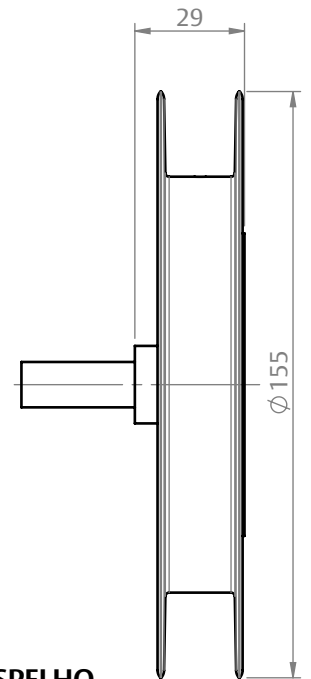

PONTEIRA OCT40

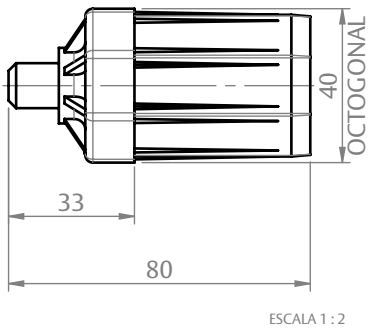

PONTEIRA C/ FURO

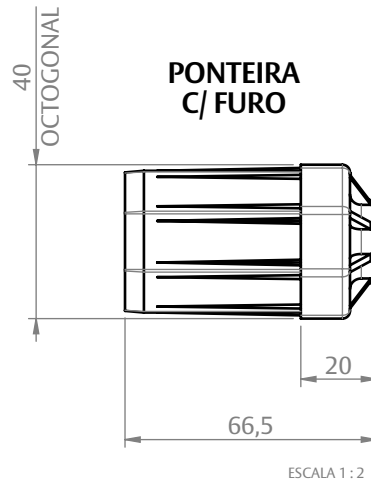

USINAGEM

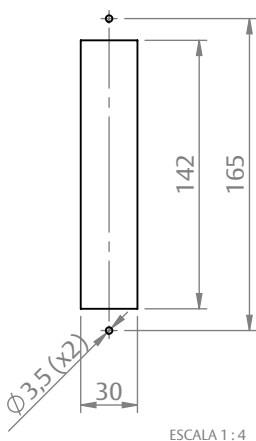

CAIXA DO RECOLHEDOR

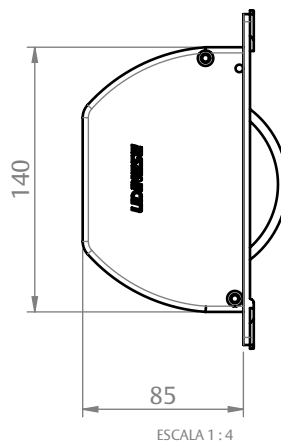

ESPELHO

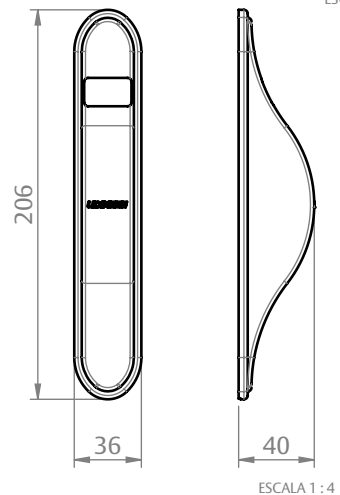

PERSIANAS

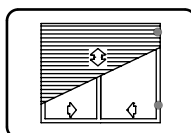

UDINESE
ASSA ABLOY

RECOLHEDOR 8155/40

OBSERVAÇÕES:

- PARA A MONTAGEM COM O TUBO OCTAGONAL DE 40 MM, SEGUIR A MESMA ORDEM DE MONTAGEM DESCONSIDERANDO OS ADAPTADORES PARA TUBO DE 60 MM.

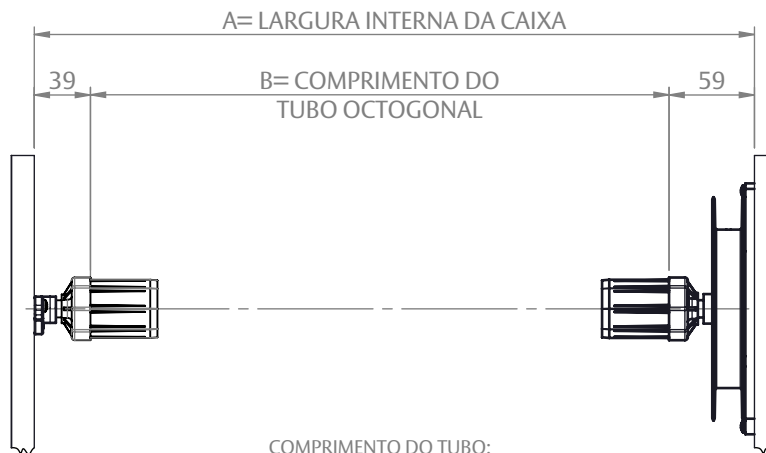
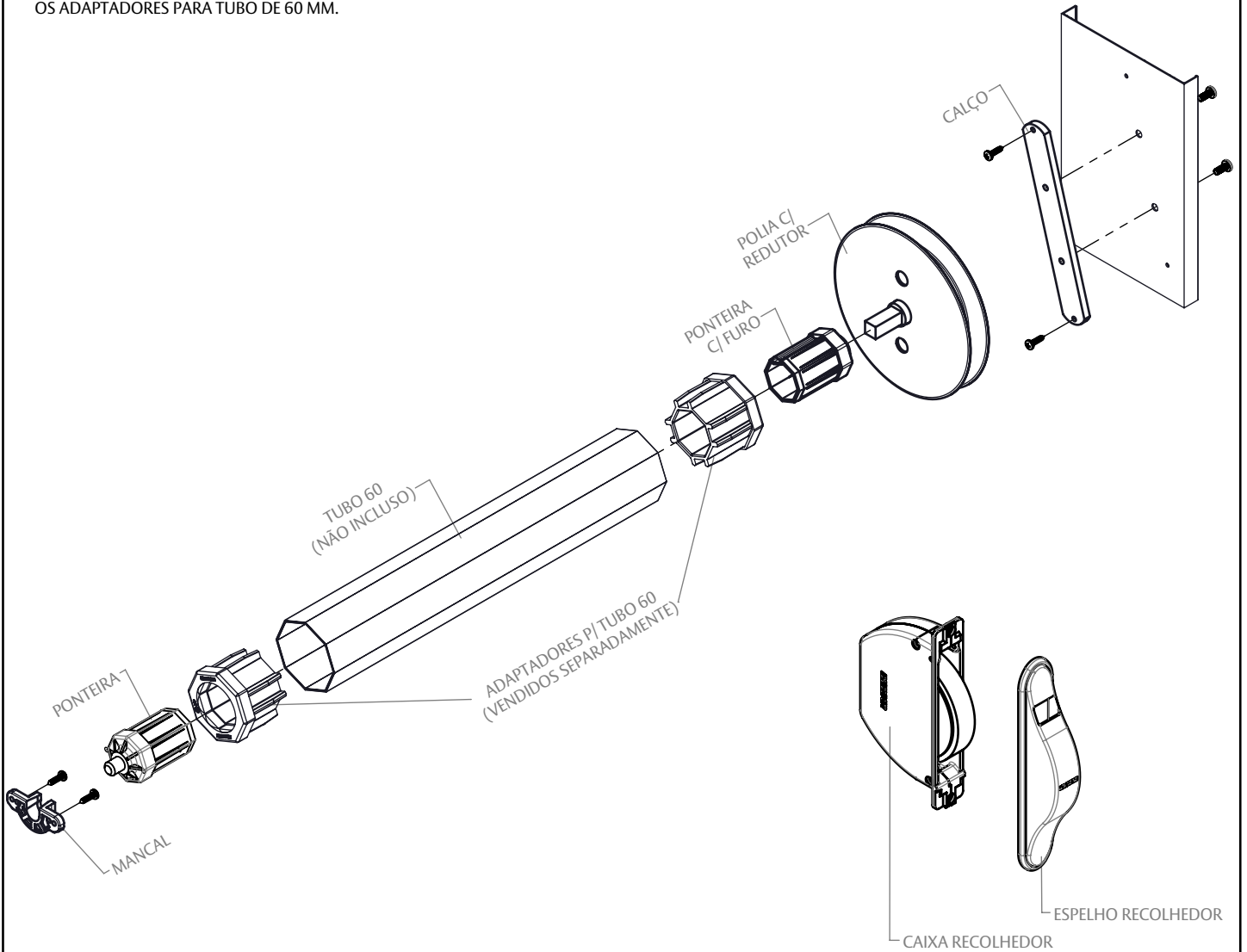

$$B = A - 98$$

UDINESE
ASSA ABLOY